



6000





Concept

Design, innovative and robust constructions, effective solutions for all applications and the unique large waste hopper make the Dulevo 6000 the perfect working tool for all seasons – everywhere and at any time - regardless of high or low temperatures, sun, rain or snow. Up to date technology and top-quality components ensure the high standards demanded by the market – a guaranty of longevity.



Comfort

Operators comfort and ergonomics are our priority together with application specifications. Effective axle suspensions and ideal weight distribution insure a balanced and safe drive ability. The powerful drive transmission guarantees the use in difficult conditions and on slopes too. The hydraulically assisted and the synchronized four-wheel-steering greatly simplifies complex manoeuvres.



Cabin

The generous interior space of the cabin and the quality seats make the machine an extremely comfortable workplace. An additional insulation and springs protect the operator from noise emissions and vibrations.

The large window surfaces of the cab allow the all-round view of the working area. The standard equipment includes heated mirrors, air condition and a charging plug for mobile devices.



Access & Service

The innovative, modular structure with the unique tiltable cabin and the on-top-centred position of all main components allow the most simple access to all important components for service and maintenance. Dulevo 6000 is fully hydrostatic driven without the use of any electronic components.



Environment

Dulevo and environmental awareness belongs together since several time. Lowest noise, dust emission, lowest water and fuel consumption are the basic concept of Dulevo 6000. With a proofed fine dust reduction of 100% (compared to standard suction sweeping equipment) and a water saving of up to 60%, Dulevo 6000 fulfils all the environmental future demands.

Fine dust emissions – System related differences:

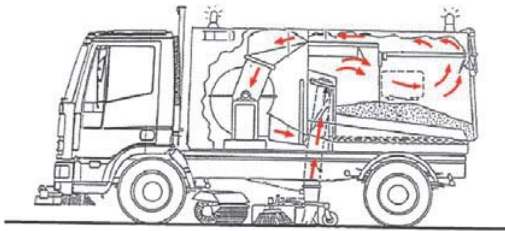

Traditional suction system

Traditional filter

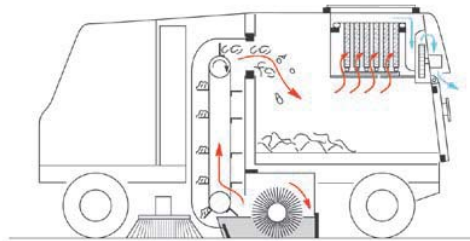

Dulevo Patented Mechanical-suction-filter system

Dulevo filter



Dulevo International unique filtration technology

In cooperation with Gore® Dulevo developed the only worldwide existing full fine dust filtration sweeper. This mechanical-suction-filtration system grants with the exclusive application of the Gore® technology a total abatement of PM10 particles.

Further benefits of the filter technology are:

- No Maintenance
- Self cleaning effect
- Highest proofed absorbing of PM10 / PM5 / PM2,5 / PM 1
- 5 Years Warranty
- Granted constant & durable filtering
- 35 % higher Airflow
- Resistance against water, oil, fats, chemical agents, etc

GORE dust filters installed in the industrial sweeper have 5 YEARS warranty.



FILTERING CAPACITY (with Certificate of conformity issued by TÜV and DNV)	
	Fraction with granulometry < 1 µm 58%
	Fraction with granulometry < 2,5 µm 92%
	Fraction with granulometry < 5 µm 98%
	Fraction with granulometry < 10 µm >99%



Application

The 180-degree full motion massive front brush is an indispensable auxiliary tool for sweeping corners, gutters and for increasing working width.

Dumping Height – USA standards

For the American market, Dulevo designed a specific optional in order to accomplish US standards for street sweepers. Dumping height can vary from 45.3 inches to up to 118.11 inches, facilitating therefore the unload of the collected debris in a high-capacity container.



Security

One of Dulevo priority has always been the safety in the working environment of the machine. Dulevo 6000 is equipped with a reverse camera with a colour screen in the cabin next to an acoustical warning.

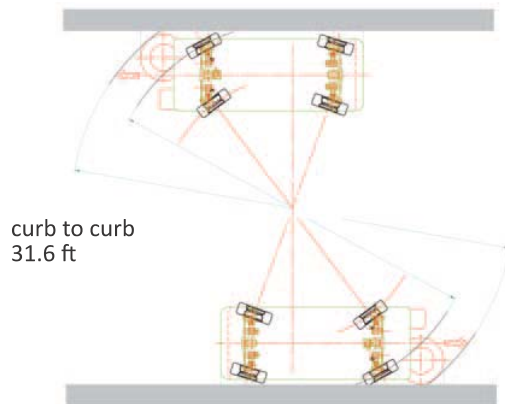
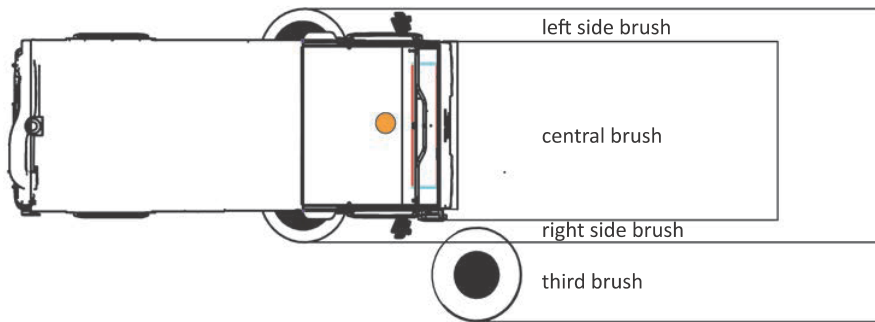

TECHNICAL DATA		6000
Sweeping width		
- With central brush	in	51.2
- With side brushes	in	102.4
- With third brush	in	137.8
Waste container capacity	yd ³	8.2
Dumping height	in	45.3
Dumping height (opt)	in	90.6 - 118.2
Seats in the cabin	n°	2 o 3 (opt)
Cleaning performance	ft ² /h	1,129,800
Maximum speed	mph	20
PM 10 filtration	%	99
Engine Brand		CUMMINS
Fuel		DIESEL
Length	in	233.1
Width	in	92.6
Height	in	117.8

Texas Region Contact Information
Local Dealer: Pannell Industries II, LLC

Office: (214) 388-9999 **Fax:** (214) 388-9998 **Mobile:** (214) 801-8001

Email: sales@pibroom.com

Address: 4361 Cedar Lake Dr, Dallas, TX 75227

